

C1098 JPEG Module

User Manual

General Description

C1098 is VGA camera module performs as a JPEG compressed still camera that can be attached to a wireless or PDA host. Users can send out a snapshot command from the host in order to capture a full resolution single-frame still picture. The picture is then compressed by the JPEG engine and transferred to the host thru serial port.

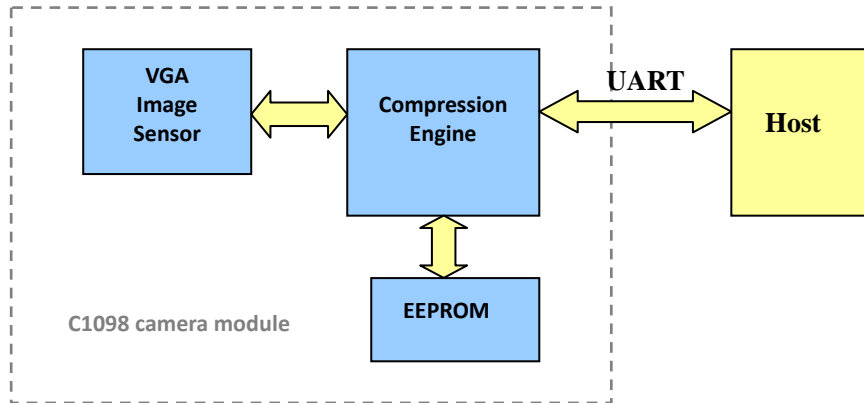

Figure 1 – System block diagram

Features

- ✚ Small in size, 20mm×28mm
- ✚ VGA resolution, down sample to QVGA
- ✚ 3.3V operation
- ✚ Low power consumption
- ✚ User friendly commands to control the module
- ✚ UART interface of up to 460.8Kbps
- ✚ Various lens options

Board Layout

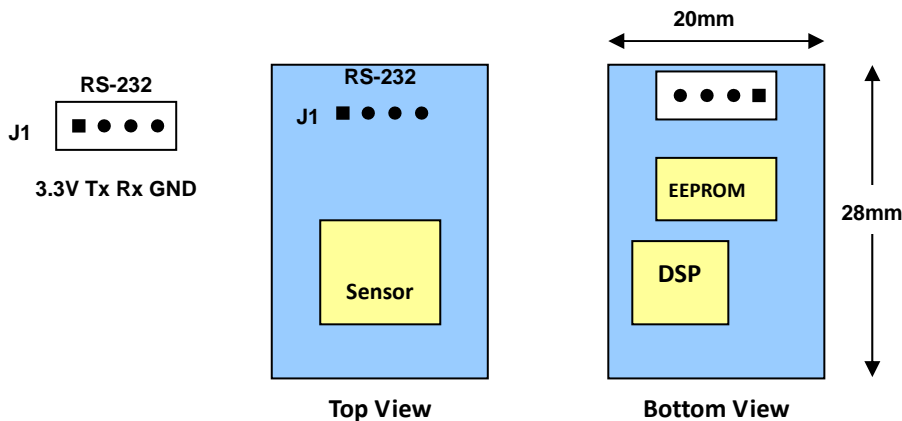

Figure 2 – C1098 board layout and serial interface pin assignment

Pin	VCC	TxD	RxD	GND
Description	Power 3.3V DC	Data transmit (3.3V)	Data receive (3.3V)	Power Ground

Serial Interface

1. Baud Rate

C1098 supports total 6 types of baud rate: 460,800bps, 230,400bps, 115,200bps, 57,600bps, 28,800bps and 14,400bps. **Default** baud rate is **14,400bps**. In other words, host needs to sync with module using 14,400bps when power up. After connection, host can change baud rate to other value.

2. Single Byte Timing Diagram

A single byte RS-232 transmission consists of the start bit, 8-bit contents and the stop bit. A start bit is always 0, while a stop bit is always 1. LSB is sent out first and is right after the start bit.

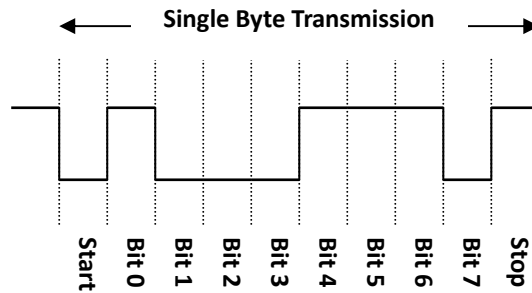

Figure 3 – RS-232 single byte timing diagram

3. Command Timing Diagram

A single command consists of 6 continuous single byte RS-232 transmissions. The following is an example of **SYNC** (AAh, 0Dh, 00h, 00h, 00h, 00h) command.

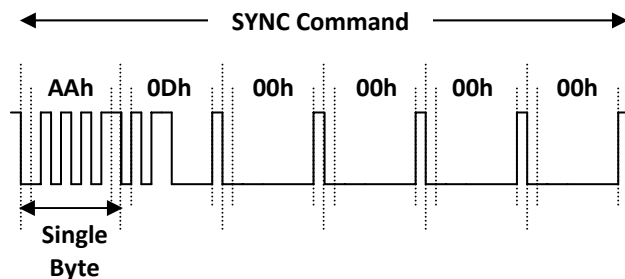

Figure 4 – RS-232 SYNC command timing diagram

Command Summary

Command	Function
INITIAL	Configure interface speed , image size
GET PICTURE	Get image from the module
SNAPSHOT	Capture a still image
SET PACKAGE SIZE	Set the package size to transmit data from module to the host
RESET	Reset the whole system
DATA LENGTH	Provide the data length information
SYNC	Start a synchronization sequence
ACK	Indicate the communication success
NAK	Indicate the communication fail with error code

Command Set

Command	ID	Parameter1	Parameter2	Parameter3	Parameter4
INITIAL	0x01	Interface Speed	0x07	0x00	07-VGA 05-QVGA
Get Picture	0x04	0x01	0x00	0x00	0x00
Snapshot	0x05	0x00	0x00	0x00	0x00
Set Package Size	0x06	0x08	Package Size Low Byte	Package Size High Byte	0x00
Reset	0x08	0x00	0x00	0x00	Reset Priority
DATA LENGTH	0x0A	0x01	Length Byte 0	Length Byte 1	Length Byte 2
SYNC	0x0D	0x00	0x00	0x00	0x00
ACK	0x0E	Command ID	ACK counter	0x00/Package ID Byte0	0x00/Package ID Byte 1
NAK	0x0F	Command ID	NAK counter	Error Code	0x00

Note: user should follow the listed values of parameter. All other values not stated are invalid and may cause unexpected failure.

1. INITIAL Command (ID0x01):

The INITIAL command is used to set up the image resolution and baud rate. Host should send INITIAL command before it wants to change baud rate or image resolution.

1.1 Command Format: AA 01 p1 07 00 p4 where p1 is interface speed and p4 is size of JPEG.

1.1.1 P1 – Interface Speed:

For the UART interface, Interface Speed is the index of baud rate. The relationship between Interface Speed and the baud rate is shown in table 1-1.

Table 1-1 P1 of Initial Command: Interface Speed

Interface Speed	Baud Rate (bps)
0x07	14400
0x06	28800
0x05	57600
0x04	115200
0x03	230400
0x02	460800

Note: other speeds than listed are not supported.

1.1.2 P4 - JPEG Resolution:

The JPEG Resolution specifies the image size.

Table 1-2 P4 of Initial Command: JPEG Resolution

Resolution	Definitions
320x240 (QVGA)	0x05
640x480 (VGA)	0x07

1.2 Communication Protocol

For instance: Baud Rate=115,200bps (p1=0x04),
 JPEG Resolution = 320*240 (p4=0x05)

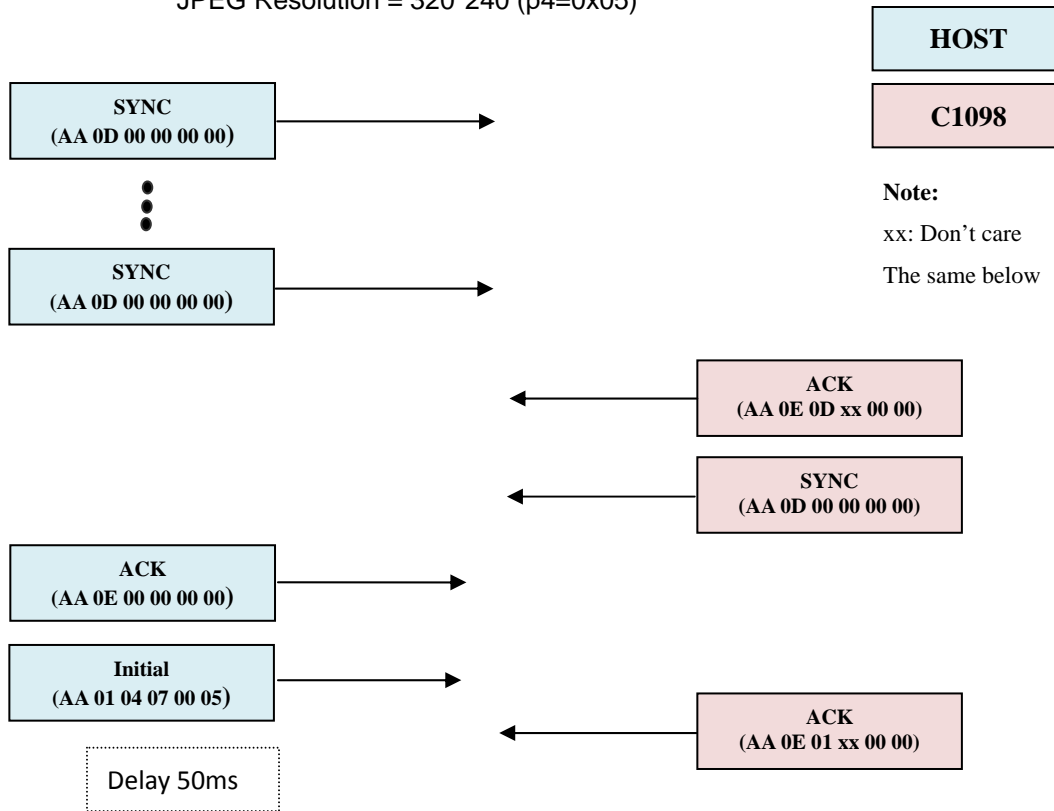

2. SET PACKAGE SIZE (ID 0x06)

The host issues this command to change the size of data package which is used to transmit JPEG image data from the C1098 to the host. This command should be issued before sending Snapshot command or Get Picture command to C1098. Note that the size of the last package varies for different image.

2.1 Command format: AA 06 08 p2 p3 00 where p3 (high byte), p2 (low byte) are package size. If not set, the default size is 64bytes. The max package size can be FF 00.i.e. 64K bytes

2.1.1 Package Data:

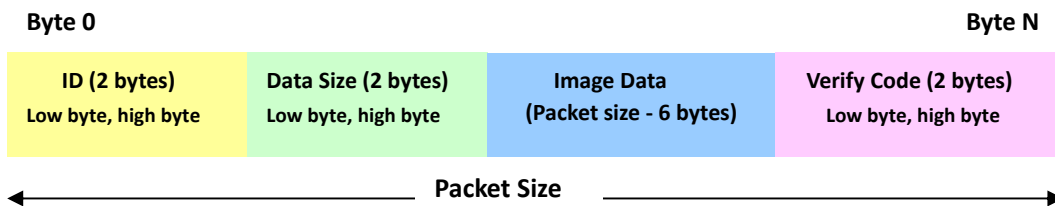

Figure 5 – Data Packet sequence diagram

2.2

ID	-> Data Packet ID, starts from 0000h to F0F0h
Data Size	-> Actual size of available image data in the packet
Image Data	-> Available image data
Verify Code	-> Error detection code, equals to the lower byte of sum of the whole data packet except the verify code field. The higher byte of this code is always zero. i.e. verify code = low byte(sum(byte[0] to byte[N-2]))

Communication Protocol:

For instance: The host to set the package size = 512 bytes, change p3 & p2 to 02 00.

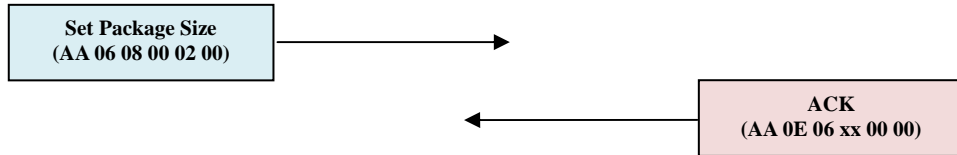

3. GET PICTURE Command (ID 0x04)

Host can get image form C1098 by this command.

3.1 Command format: AA 04 01 00 00 00

3.2 Communication Protocol:

Below is an example of getting the picture continuously

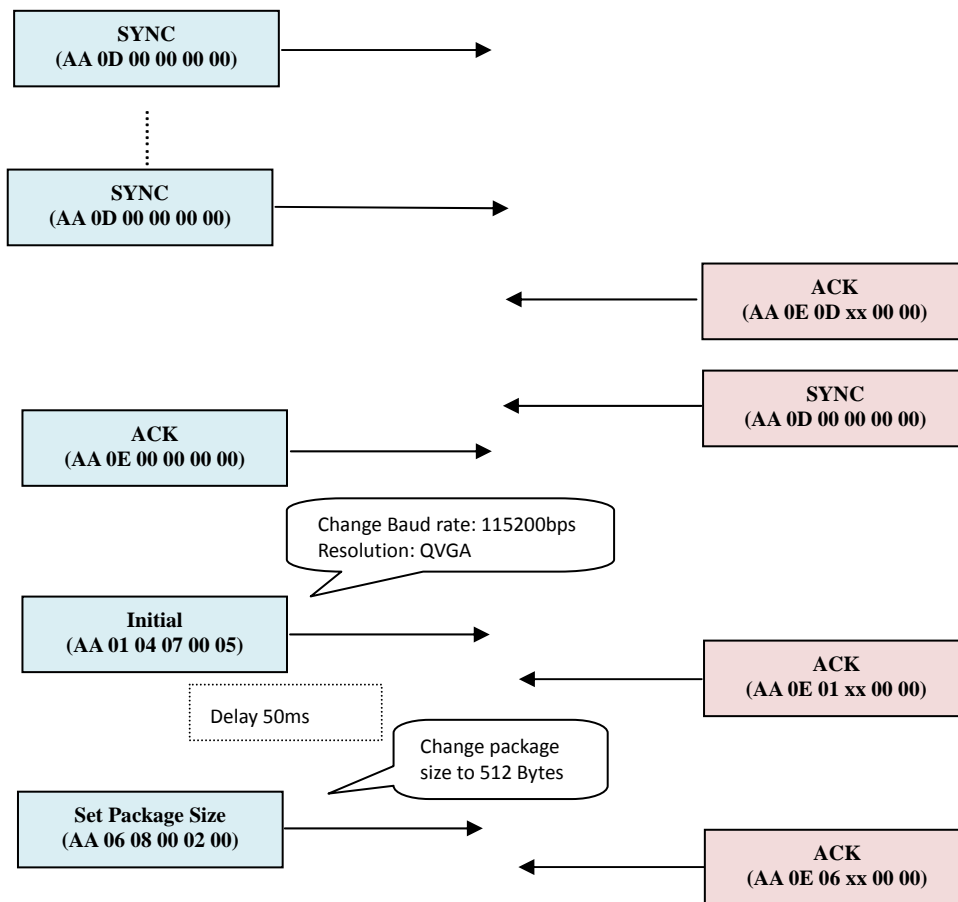

To be continued next page

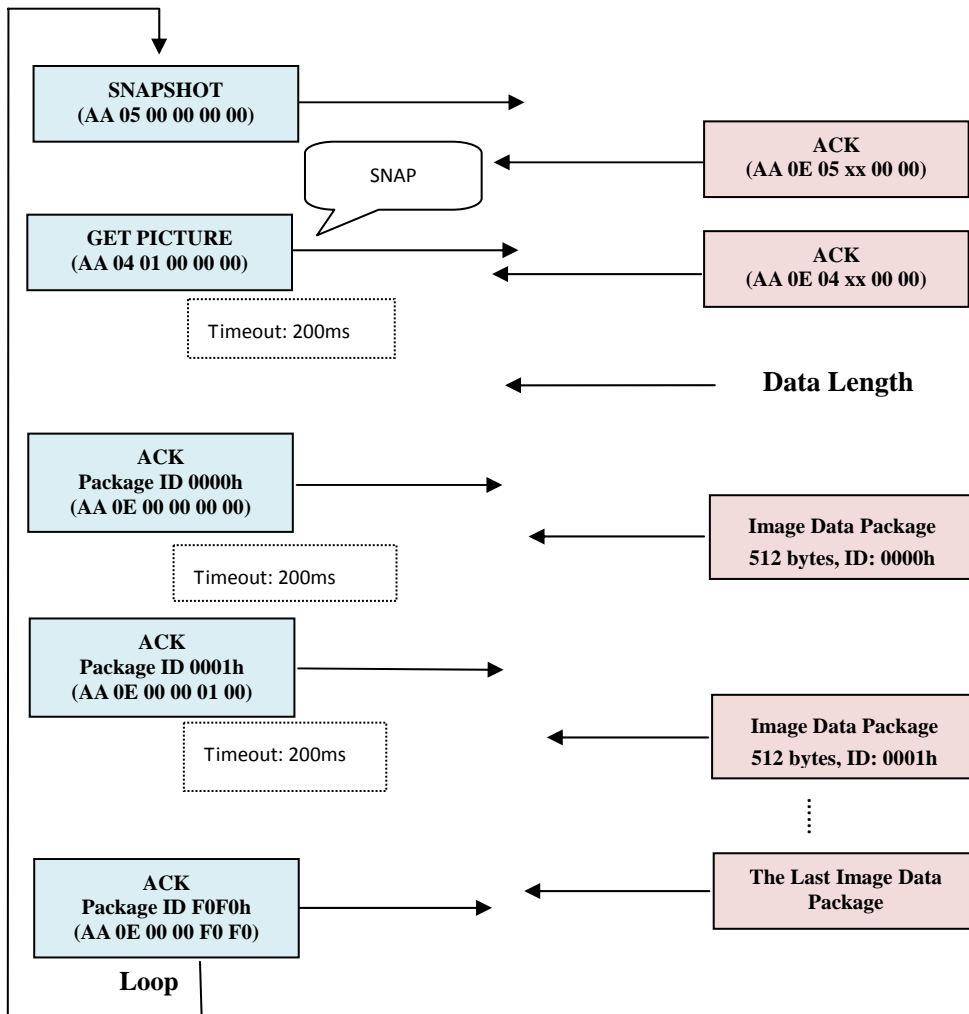

Note:

The timeout value is the maximum time to encode a JPEG image needs. If C1098 has no response in the due time, send command RESET and retry the process.

4. SNAP SHOT Command (ID 0x05)

The host sends this command to ask C1098 to capture a still jpeg image. Image data will be stored in buffer and waiting for sending.

4.1 Command format: AA 05 00 00 00 00

4.2 Communication Protocol:

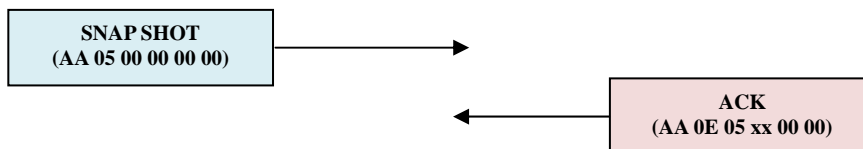

5. RESET Command (ID 0x08)

This command is used to reset C1098.

5.1 Command Format: AA 08 00 00 00 p4 where p4 is priority

5.1.1 P4 – Reset Priority:

Normal Priority: 0x00 **High Priority:** 0xFF

If the p4 is normal priority, C1098 will finish current operation, then reset. If the p4 has been set to high priority, C1098 will reset immediately.

5.2 Communication Protocol:

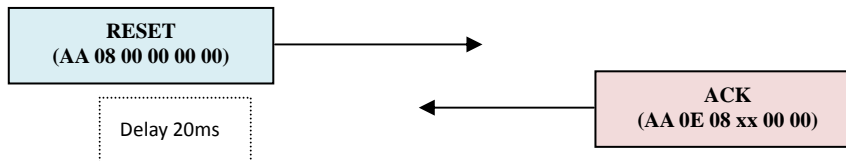

Note:

Reset command is only used to reset the hardware of C1098, will not reset the parameters. Reset command can also be used to stop getting image data. When in the circulation of getting JPEG image, Host could send command RESET to stop the process. Please delay at least 20ms to send another command after sending RESET.

6. DATA LENGTH Command (ID 0x0A)

Data length is stand for image file size. When GETPICTURE command is issued by host, the module will ACK and send DATA LENGTH with data length information.

6.1 Command Format: AA 0A 01 p2 p3, p4 where

P2 – Length Byte 0: Least Significant Byte (LSB)

P3 – Length Byte 1:

P4 – Length Byte 2: Most Significant byte (MSB).

Here is an example of getting a QVGA JPEG picture.

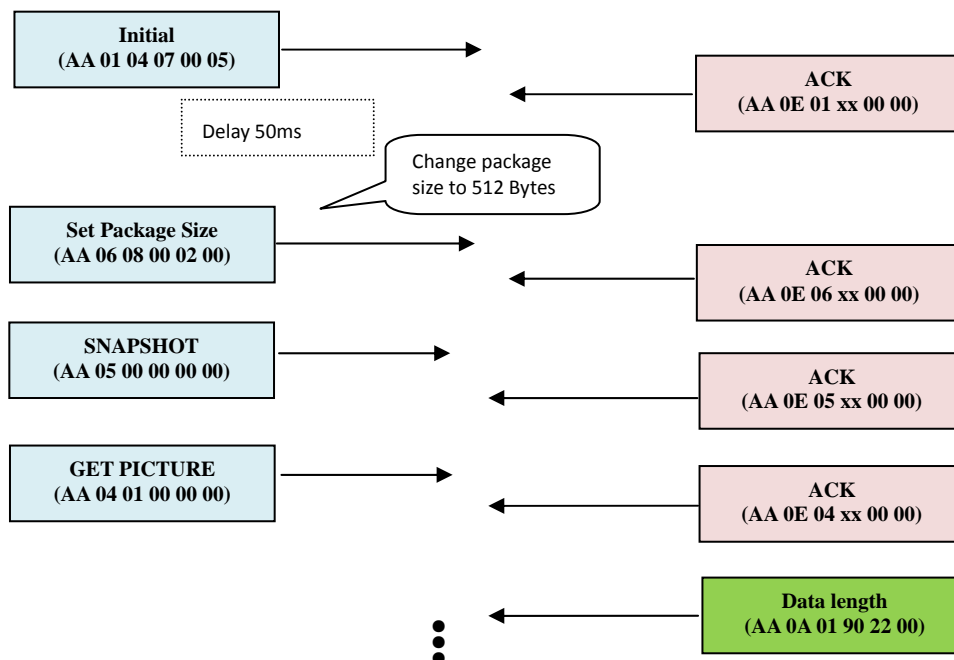

From the figure above, we get: **P2=90, P3=22, P4=00**, so the image size is 0x002290 Bytes or 8848Bytes in Decimal.

7. SYNC Command (ID 0x0D)

The host sends this command to start a synchronization sequence.

7.1 Command Format: AA 0D 00 00 00 00

7.2 Communication Protocol:

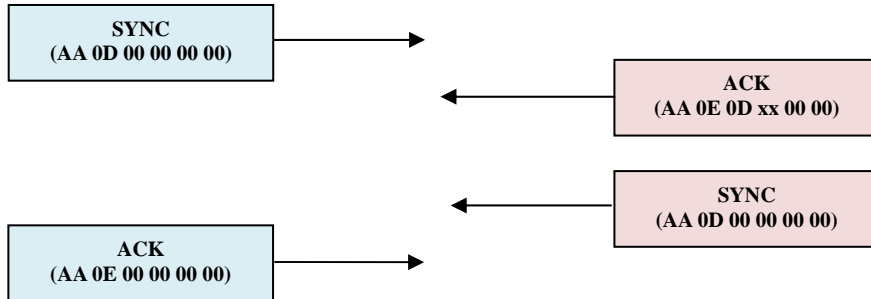

7.3 Make Connection with C1098

Send the SYNC command until receiving ACK command from C1098. This must be done after power up.

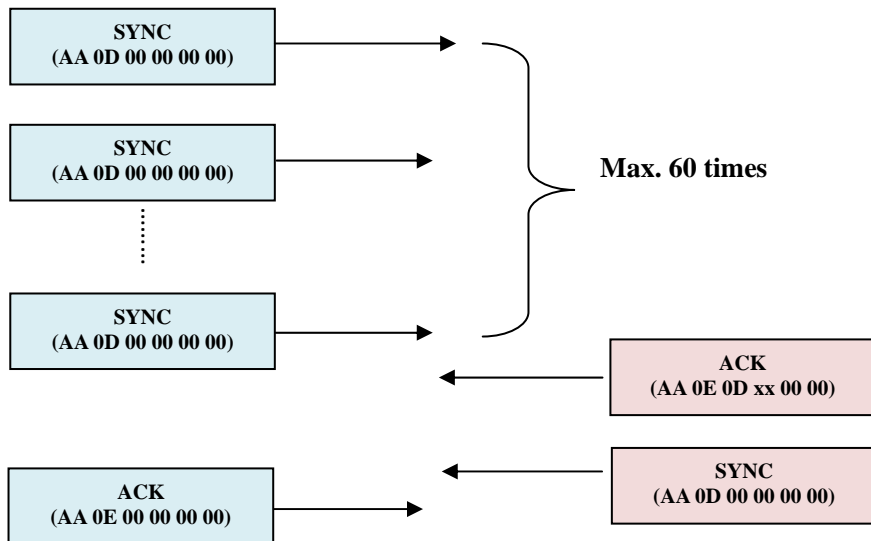

8. ACK Command (ID 0x0E)

This command is a handshake command, which means command or data is received correctly.

8.1 Command Format: there are 2 types of ACK.

8.1.1 One is for acknowledge the command: AA 0E p1 p2 00 00 where p1 is command ID and p2 is ACK counter, the counter will be increased by 1 after ACK command sent

8.1.2 The other is for issuing package ID when getting image data: AA 0E 00 00 p3 p4 where p3(byte0) and p4(byte1) is package ID

Below is the example of Package ID and relevant command:

Package ID	Command	Module response
0001	AA 0E 00 00 01 00	Image data package ID0001
0102	AA 0E 00 00 02 01	Image data package ID0102
F0F0	AA 0E 00 00 F0 F0	No response

8.2 Calculation of Package Number

Number of package = Image size / (Package size - 6)

For example: Assume Image size = 0x4380; (From DATA LENGTH command)

Package size = 0x0200; (From SET PACKAGE SIZE command)

Number of package = $0x4380 / (0x0200 - 6) = 0x22 + 1$.

(there is remainder so, need to add 1)

In other words, we need to send 35 times of ACK to get the whole image. One can increase the package size and shorten the get image time. However, it needs the hardware support.

9. NAK Command (ID 0x0F)

This command is a handshake command, which indicates corrupted transmissions or unsupported features.

9.1 Command Format: AA 0F p1 p2 p3 00 where p1 is ID, p2 is NAK counter and p3 is error code

9.1.1 P3 – Error Code:

Parameter 3	Description
0Bh	Parameter Error
0Dh	Command ID Error
F0h	Command Header Error
11h	Set Transfer Package Size Wrong

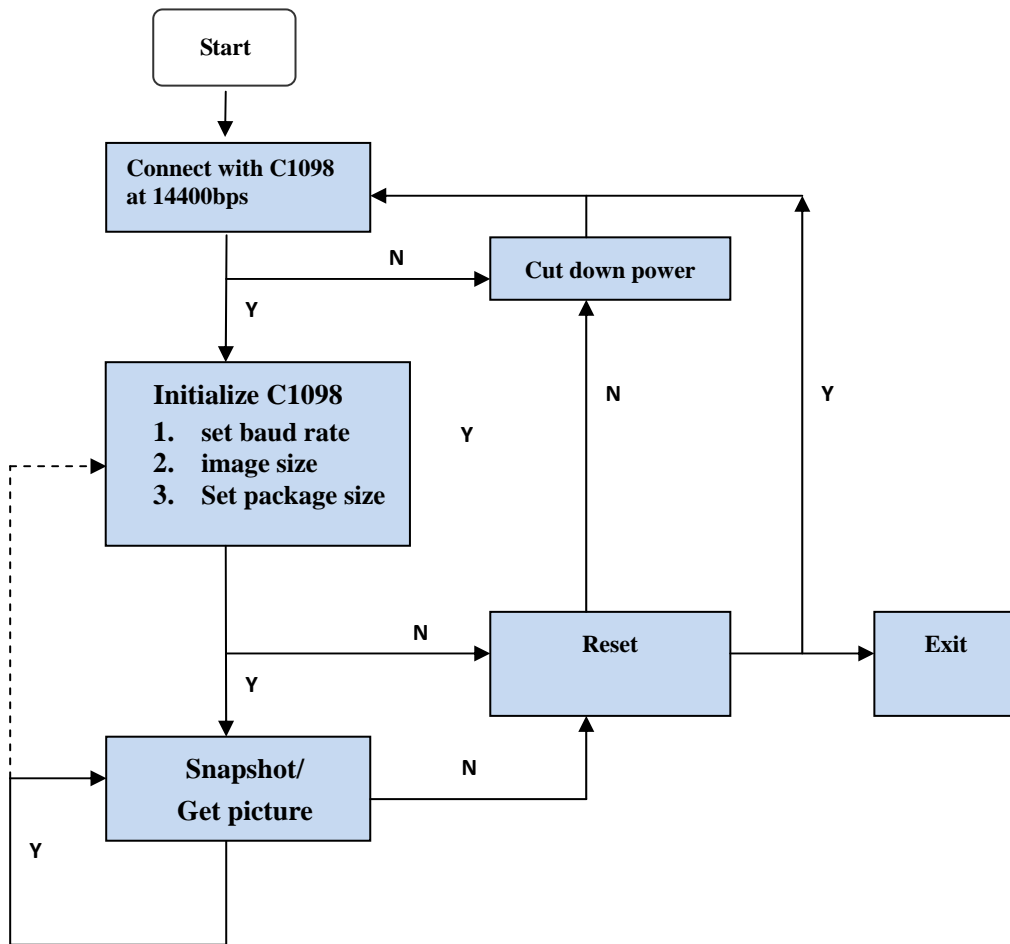
Appendix A – Flow Diagram:

Appendix B: Example to Get a QVGA JPEG image @460800bps

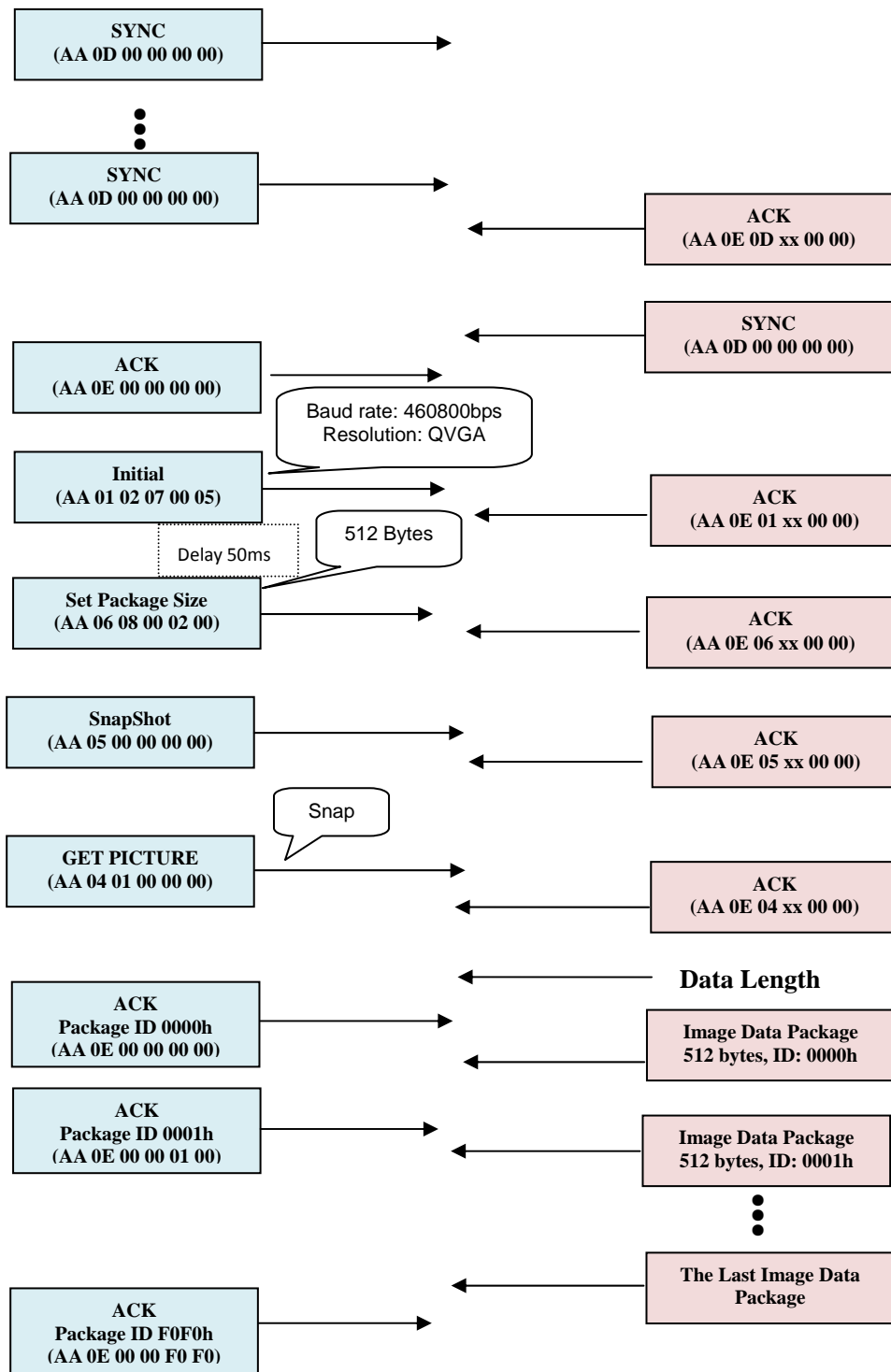

These are package data that were got from C1098:

Package 00:

```
00 00 FA 01 FF D8 FF E0 00 11 4A 46 49 46 00 01 01 01 00 00 00 00 00 00 0A FF DB 00 43 00 08 06 06 07 06 05 08 07 07 07
09 09 08 0A 0C 14 0D 0C 0B 0B 0C 19 12 13 0F 14 1D 1A 1F 1E 1D 1A 1C 1C 20 24 2E 27 20 22 2C 23 1C 1C 28 37 29 2C 30
31 34 34 34 1F 27 39 3D 38 32 3C 2E 33 34 32 FF DB 00 43 01 09 09 09 0C 0B 0C 18 0D 0D 18 32 21 1C 21 32 32 32 32 32
32 32 32 32 32 32 32 32 32 32 32 32 32 32 32 32 32 32 32 32 32 32 32 32 32 32 32 32 32 32 32 32 32 32 32 32
32 32 32 FF C4 00 1F 00 00 01 05 01 01 01 01 01 01 00 00 00 00 00 00 00 01 02 03 04 05 06 00 08 09 0A 0B FF C4 00 B5
10 00 02 01 03 03 02 04 03 05 05 04 04 00 00 01 7D 01 02 03 00 04 11 05 12 21 31 41 06 13 51 61 07 22 71 14 32 81 91 A1 08
23 42 B1 C1 15 52 D1 F0 24 33 62 72 82 09 0A 16 17 18 19 1A 25 26 27 28 29 2A 34 35 36 37 38 39 3A 43 44 45 46 47 48 49
4A 53 54 55 56 57 58 59 5A 63 64 65 66 67 68 69 6A 73 74 75 76 77 78 79 7A 83 84 85 86 87 88 89 8A 92 93 94 95 96 97 98 99
9A A2 A3 A4 A5 A6 A7 A8 A9 AA B2 B3 B4 B5 B6 B7 B8 B9 BA C2 C3 C4 C5 C6 C7 C8 C9 CA D2 D3 D4 D5 D6 D7 D8 D9
DA E1 E2 E3 E4 E5 E6 E7 E8 E9 EA F1 F2 F3 F4 F5 F6 F7 F8 F9 FA FF C4 00 1F 01 00 03 01 01 01 01 01 01 01 01 00 00
00 00 00 01 02 03 04 05 06 07 08 09 0A 0B FF C4 00 B5 11 00 02 01 02 04 04 03 04 07 05 04 04 00 01 02 77 00 01 02 03 11
04 05 21 31 06 12 41 51 07 61 71 13 22 32 81 08 14 42 91 A1 B1 C1 09 23 33 52 F0 15 62 72 D1 0A 16 24 34 E1 25 F1 17 18
19 1A 26 27 28 29 2A 35 36 37 38 39 3A 43 44 45 46 47 48 49 4A 53 54 55 56 57 58 59 5A 63 64 65 91 00
```

Package 01:

```
01 00 FA 01 66 67 68 69 6A 73 74 75 76 77 78 79 7A 82 83 84 85 86 87 88 89 8A 92 93 94 95 96 97 98 99 9A A2 A3 A4 A5 A6
A7 A8 A9 AA B2 B3 B4 B5 B6 B7 B8 B9 BA C2 C3 C4 C5 C6 C7 C8 C9 CA D2 D3 D4 D5 D6 D7 D8 D9 DA E2 E3 E4 E5 E6 E7
E8 E9 EA F2 F3 F4 F5 F6 F7 F8 F9 FA FF C0 00 11 08 00 F0 01 40 03 01 22 00 02 11 01 03 11 01 FF DA 00 0C 03 01 00 02 11
03 11 00 3F 00 F4 C5 51 9A 9D 48 15 58 35 29 93 03 AD 07 31 70 30 A7 82 2A 8A 4A C3 DE A5 12 9C 66 80 B1 6F 23 14 81
C5 55 12 9F 5A 77 99 9E F4 05 8B 80 E6 9D 8C D5 3F 30 91 C3 01 4E 59 D1 7E F4 83 F3 A5 71 16 1F 01 6A 25 28 C7 81 83
50 BD DD AA B1 2D 73 18 F6 DC 2A AB EA 9A 64 47 73 5E 46 31 FE D5 01 74 69 A9 2A 71 56 15 F0 39 35 CF BF 8A B4 88
C7 37 B1 71 EF 55 9F C7 3A 1A F5 BB 53 F4 34 59 85 D1 D6 2C 99 E9 52 A3 1E F5 C3 B7 C4 6D 12 1E 92 13 55 A4 F8 A9 A5
C7 F7 11 98 FD 29 D9 87 C8 F4 50 FE D4 E0 72 2B CB 64 F8 B9 00 CE CB 56 3F 85 54 93 E2 D4 A7 FD 5D B7 3E F4 59 85
A5 D8 F5 E0 00 A3 35 E2 B2 FC 57 D4 5B EE 42 A3 EA 6A B3 7C 4E D5 E4 07 EE AF A7 34 58 2D 2E C7 B9 96 00 75 A6 F9
8B 8F BC 3F 3A F9 FA 7F 88 3A E4 B9 02 70 BF 9D 42 BE 37 D6 55 48 6B 82 C4 D1 61 72 C8 FA 09 AE E1 8F EF 4A 83 EA
69 8D AA 59 28 E6 E2 3F CE BE 70 97 C4 3A A4 CC 4B 5E 4B CF A1 C5 40 35 6B E3 90 6E A5 39 F5 6A 34 1F 24 8F A2 E6
F1 0E 99 11 F9 AE 93 F3 AA 92 F8 C7 47 8B 3B AE 97 F3 AF 9E 64 BA 9A 43 97 91 89 F7 35 09 76 6E 49 26 8D 03 D9 BE E7
BE CF F1 03 44 8B 3F BF 1F 9D 51 7F 89 7A 40 07 6B E6 BC 38 9A 42 73 46 83 F6 7E 67 B3 49 F1 43 4E 27 0A B9 AC AB 9F
89 36 E9 36 F8 E0 2C 6B 73 00
```

.....

Package 16:

```
10 00 F0 00 D8 A2 E1 61 21 05 07 3D 4D 5A 46 C8 22 A0 15 2A 1C 54 B6 52 23 53 82 40 F5 A1 C8 DD 40 FB ED 48 E3 91 4D
0F A0 DD C0 D2 11 9E 45 2E 05 2E 38 A6 48 C4 18 26 9B 73 FE A5 A8 04 EF 38 A4 97 88 C9 3C D2 06 53 80 FC E7 35 68 1A
A7 13 61 EA 6F 32 99 25 EB 5F 9A 65 18 CE 4F 41 5D 15 96 95 24 E2 37 99 BC B4 6E 40 1C 92 3F A5 64 F8 7E CA 6B AB C4
B8 18 10 C2 D9 62 4F 24 E3 A0 15 D7 5B 2B C3 04 09 26 37 2E 41 C1 A2 C4 4A 6F 64 40 21 86 DB 29 12 05 F5 3D CF D6 9B
BF E6 AA 3A 95 E3 43 7C E9 DB 82 2A BA DF 12 6A 4A E8 74 96 72 61 85 6B C6 FC 57 27 69 7C 37 0E 6B 76 1B B5 20 73
54 8C D9 A7 BA 98 5A A0 17 00 8E B4 9E 68 3D E9 88 94 9A 69 34 C3 25 21 61 40 AE 29 A6 9A 42 D9 14 D2 D4 08 08 A8 C8
A7 13 4C 63 4C 57 3F FF D9 00 00 30 00
```

The different color represents the data as below:

Packet ID	Data Size	Available image data	Verify Code
-----------	-----------	----------------------	-------------

Then, we can combine the packet data into a JPEG picture as below procedure.
 First of all, to get rid of the packet ID, data size in the head and verify code in the end.
 Secondly, combine the available image data together.
 Finally, create a file and name it as *.JPG and put the available image data into it.
 Below is the image made from the above data.

